

# Bookbinding - Essentials

## Anatomy Of A Book

---

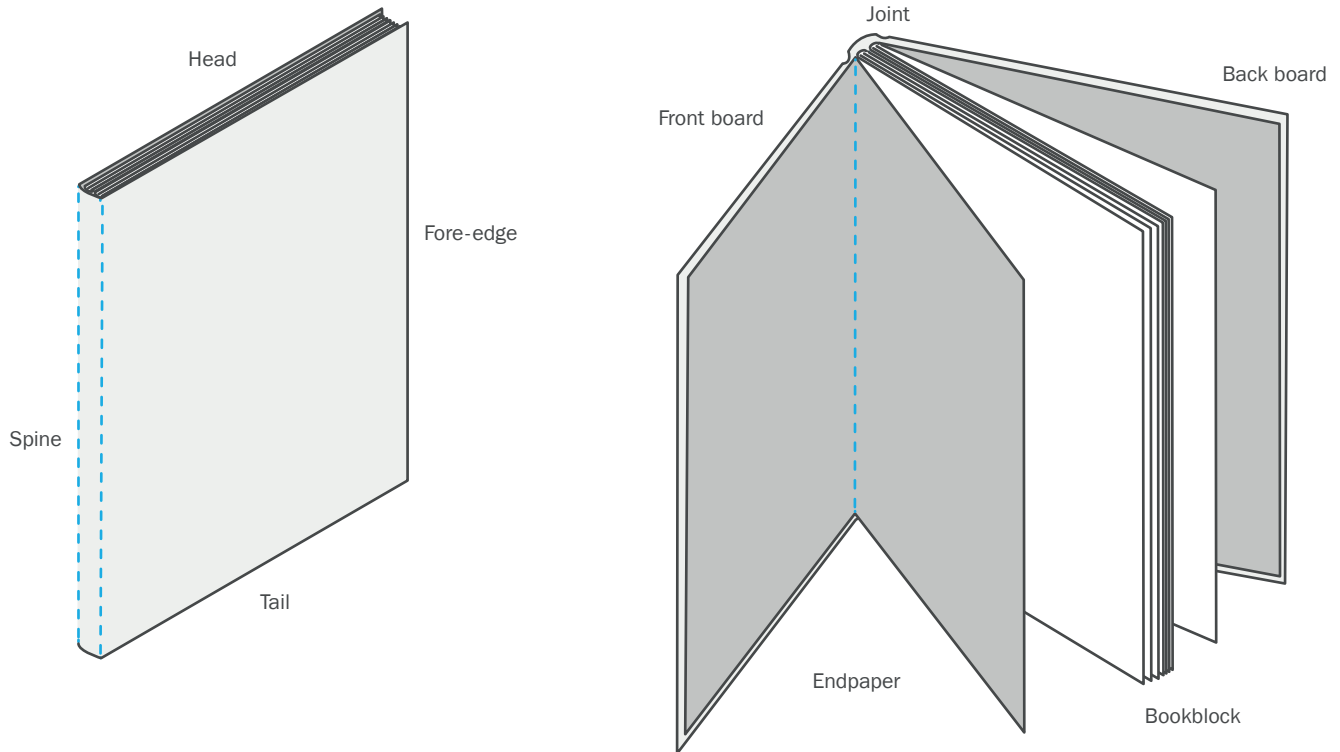

When making a book it is useful to understand its anatomy and the terminology used to describe it. The majority of books are made up of two parts; the bookblock and the case.

The 'spine' is used to describe the edge of the book where the bookblock and the case are glued together and where the book hinges to allow it to open. Opposite this is the 'fore-edge' and the top and the bottom edges of the book are called the 'head' and 'tail'.

The 'bookblock' consists of pages that are sewn or glued together. These may be single sheets as in perfect binding and stab binding techniques (lose leaf bindings). Or, the bookblock may be made up of sections.

The section (also referred to as a signature) forms the basis for most book structures. A single section being used to create pamphlet bindings or, several sections sewn together to create a multi-section binding.

A section can be made from multiple sheets of paper, folded in half (folio) and stacked inside one another. Or, as in commercial printing, sections are made by folding and slitting a large single sheet of printed paper to create a loose structure with multiple pages. This technique is recommended when larger pieces of paper are available due to its speed and ease, and especially in the creation of sketchbooks/journals. More information on folding sections can be found overleaf.

The 'case' refers to the outer cover to which the bookblock is attached to protect the pages. This can be a traditional hardback or a soft wrap-around style cover such as a Magazine. Casing-in refers to the stage of binding where the bookblock is attached to the cover either by gluing or sewing.

# Bookbinding - Essentials

## Section Folds & Impositions

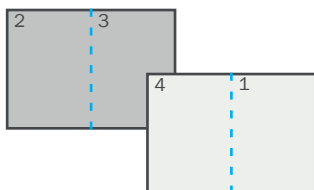

### Folio

Grain short, folded once.  
Comprised of four printed pages on two leaves.

4pp

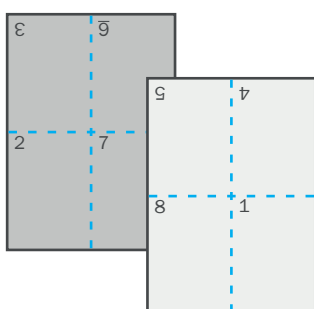
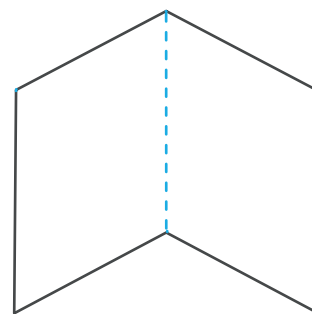

### Quarto

Grain long, folded twice.  
Comprised of eight printed pages on four leaves.

8pp

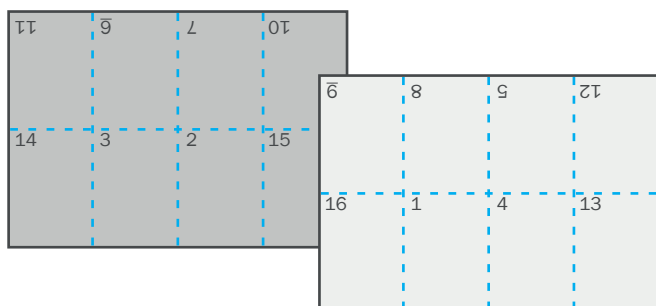
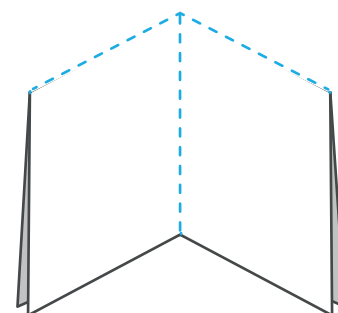

### Octavo

Grain short, folded three times  
Comprised of sixteen printed pages on eight leaves.

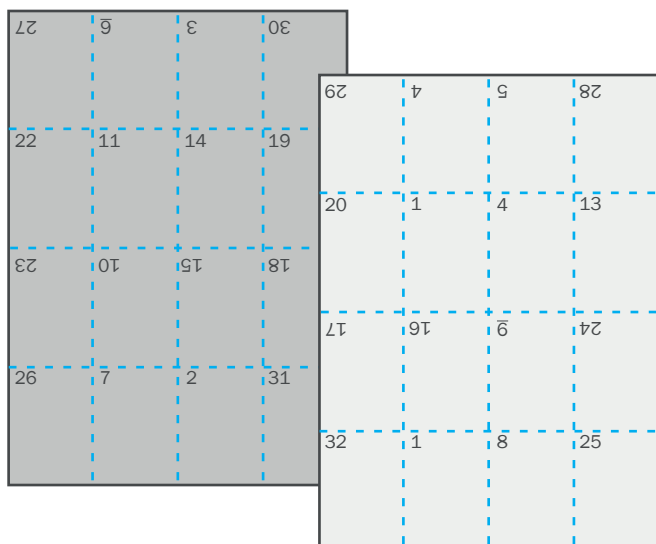
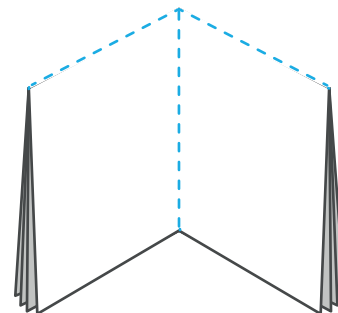

### Sextodecimo

Grain long, folded four times.  
Comprised of thirty-two printed pages on sixteen leaves.

32pp

